

Parilla X30 125cc RL-C TaG



FEATURES - CARACTERISTIQUES

Cylinder volume <i>Volume du cylindre</i>	123.67 cm ³
Bore <i>Alésage</i>	54 mm
Max. theoretical bore <i>Alésage théorique max.</i>	54.28 mm
Stroke <i>Course</i>	54 mm
Cooling system <i>Système de refroidissement</i>	Water <i>Eau</i>
Inlet system <i>Système d'admission</i>	Reed valve <i>À clapets</i>

Carburetor <i>Carburateur</i>	Tryton Hobby 27 or/ou Tryton Hobby 27/C	Cylinder / crankcase transfers n° <i>N°de canaux cylindre / carter</i>	3
Number of piston rings <i>Nombre de segments</i>	1	Inlet / exhaust ports number <i>N°lumières admiss. / échapp.</i>	3
Big end conr. ball-bearing diam. <i>Diamètre palier tête de bielle</i>	20x26x15	Combustion chamber shape <i>Forme chambre de combustion</i>	Spherical <i>Spherique</i>
Crankshaft ball-bearing diam. <i>Diamètre palier du vilebrequin</i>	30x62x16	Selettra or PVL ignition <i>Allumage Selettra ou PVL</i>	Digital
Small end conr. ball-bearing diam. <i>Diamètre palier pied de bielle</i>	14x18x17.5	RPM limiter <i>Limiteur de tours</i>	Yes <i>Oui</i>
Distance between conrod centers <i>Longueur (entre axe) de la bielle</i>	102 mm	Generator for battery charging <i>Générateur de recharge batterie</i>	Yes <i>Oui</i>
Balancing shaft <i>Arbre d'équilibrage de vilebr.</i>	Yes <i>Oui</i>	Electric starter <i>Démarrateur électrique</i>	Yes <i>Oui</i>

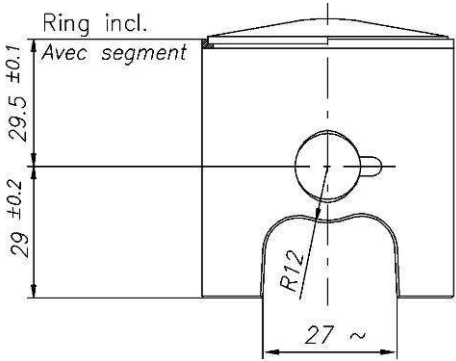
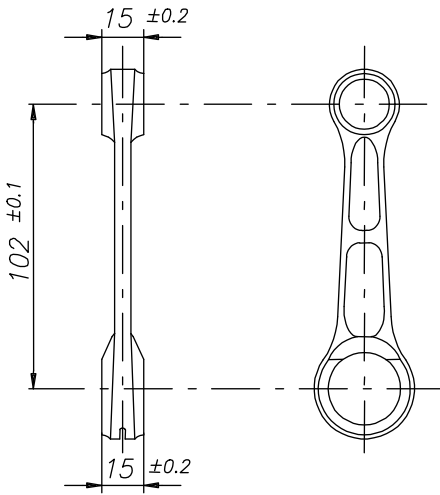
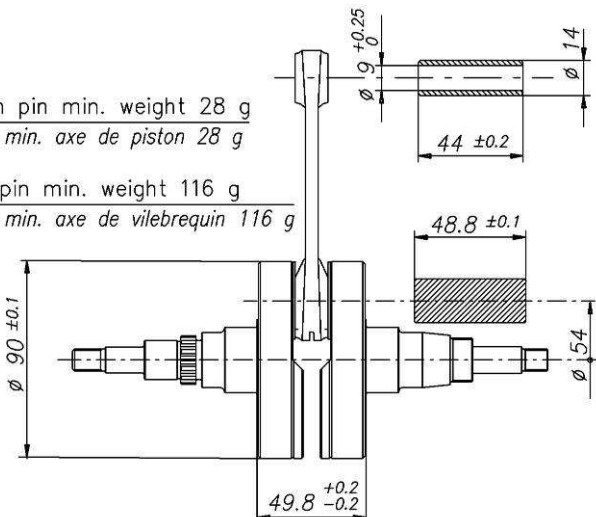
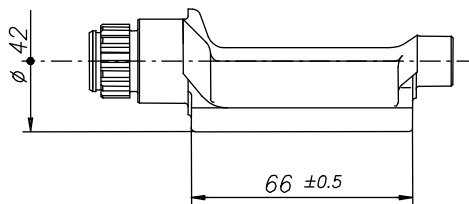
DESCRIPTION OF THE MATERIAL DESCRIPTION DES MATERIAUX		PISTON
Conrod material <i>Matériel de la bielle</i>	Steel <i>Acier</i>	 <p>Piston min. weight (ring incl.) 128 g Poids min. piston (avec segment) 128 g</p>
Crankshaft material <i>Matériel du vilebrequin</i>	Steel <i>Acier</i>	
Balancing shaft material <i>Matériel de l'arbre d'équilibrage</i>	Steel <i>Acier</i>	
Gears material <i>Matériel des engrenages</i>	Steel <i>Acier</i>	
Starter ring material <i>Matériel de la couronne démarr.</i>	Steel <i>Acier</i>	
Head material <i>Matériel de la culasse</i>	Aluminium	
Cylinder material <i>Matériel du cylindre</i>	Aluminium	 <p>Min. weight 110 g Poids min. 110 g</p>
Liner material <i>Matériel de la chemise</i>	Iron <i>Fonte</i>	
Crankcase material <i>Matériel du carter</i>	Aluminium	
Piston material <i>Matériel du piston</i>	Aluminium	
Piston rings material <i>Matériel des segments</i>	Iron <i>Fonte</i>	
Exhaust muffler material <i>Matériel du pot d'échappement</i>	Sheet-steel <i>Tôle acier</i>	
Ball-bearings <i>Roulements</i>	6206 type	
CRANKSHAFT - VILEBREQUIN		
 <p>Piston pin min. weight 28 g Poids min. axe de piston 28 g</p> <p>Crankpin min. weight 116 g Poids min. axe de vilebrequin 116 g</p> <p>Complete crankshaft min. weight 2150 g Poids min. du vilebrequin complet 2150 g</p>		 <p>Min. weight 315 g Poids min. 315 g</p>

CYLINDER DEVELOPMENT - DEVELOPPEMENT DU CYLINDRE

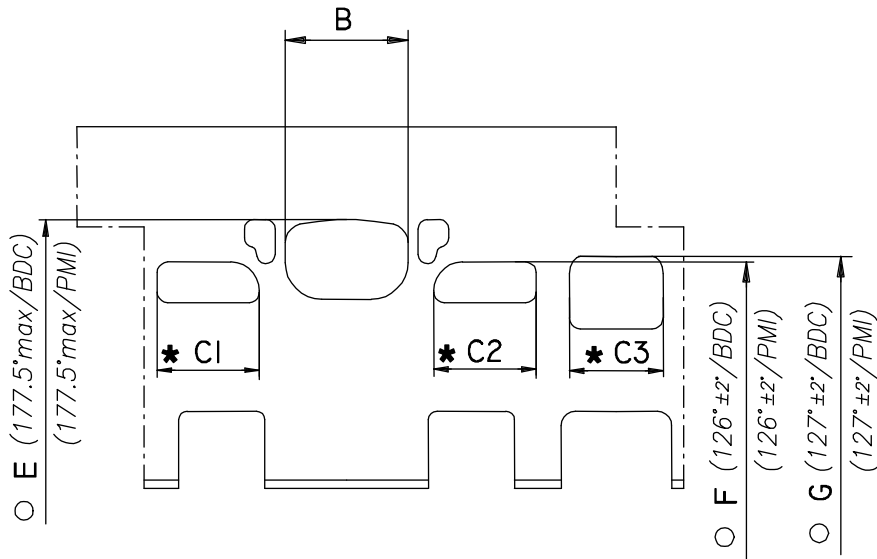

B	$\leq 36.5 \text{ mm}$
CI = C2	$\leq 30 \text{ mm}$
C3	$\leq 28.5 \text{ mm}$
E	$177.5^{\circ} \text{ max}$
F	$126^{\circ} \pm 2^{\circ}$
G	$127^{\circ} \pm 2^{\circ}$

* CHORDAL READING
LECTURE CORDALE

○ ANGULAR READING BY INSERTING A 0.2 mm GAUGE
LECTURE ANGULAIRE PAR INSERTION D'UNE CALE DE 0.2 mm

CYLINDER BASE VIEW
VUE DE LA BASE DU CYLINDRE

CYLINDER CROSS SECTION VIEW
VUE EN SECTION DU CYLINDRE

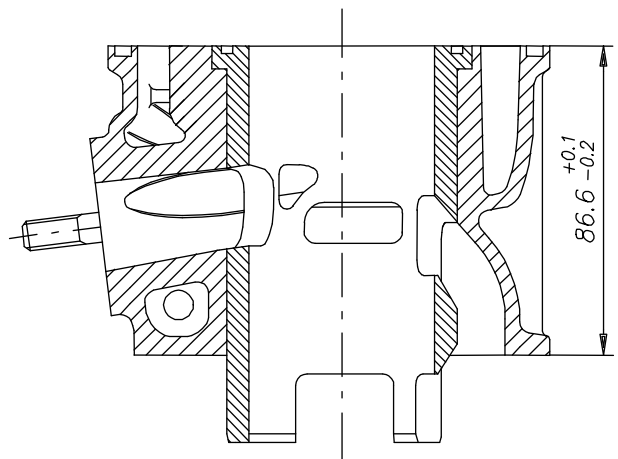
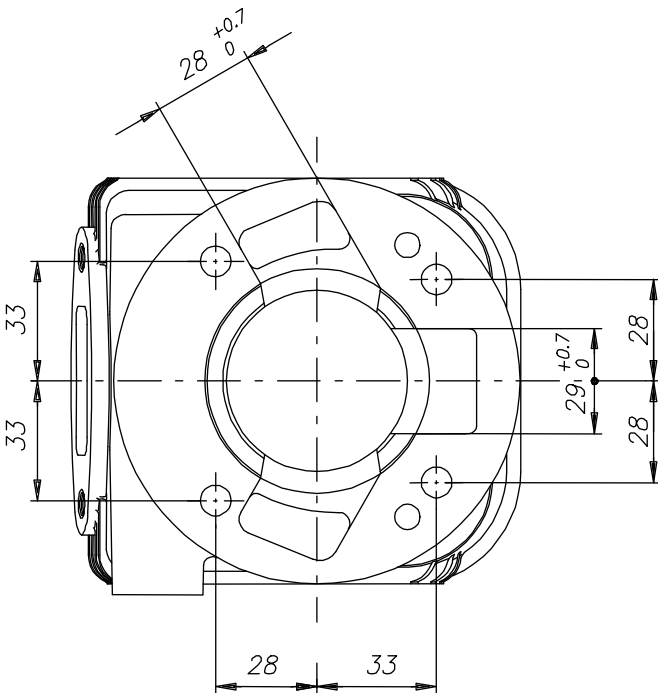

DESCRIPTION OF THE CLUTCH - DESCRIPTION DE L' EMBRAYAGE

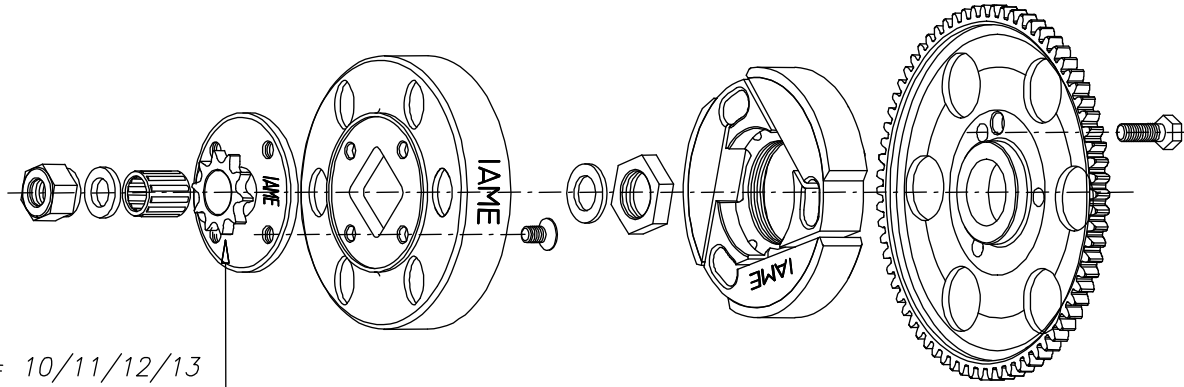

Z= 10/11/12/13

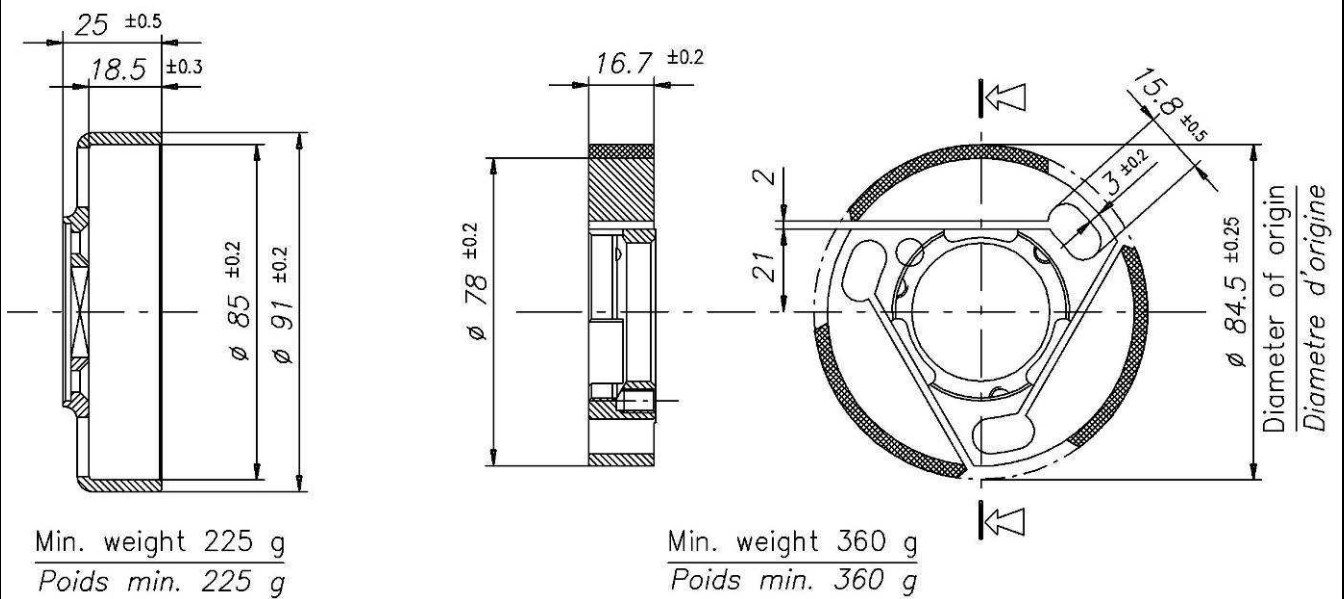

EXHAUST MUFFLER VIEW AND DIMENSIONS
VUE ET DIMENSIONS DU SILENCIEUX D' ECHAPPEMENT

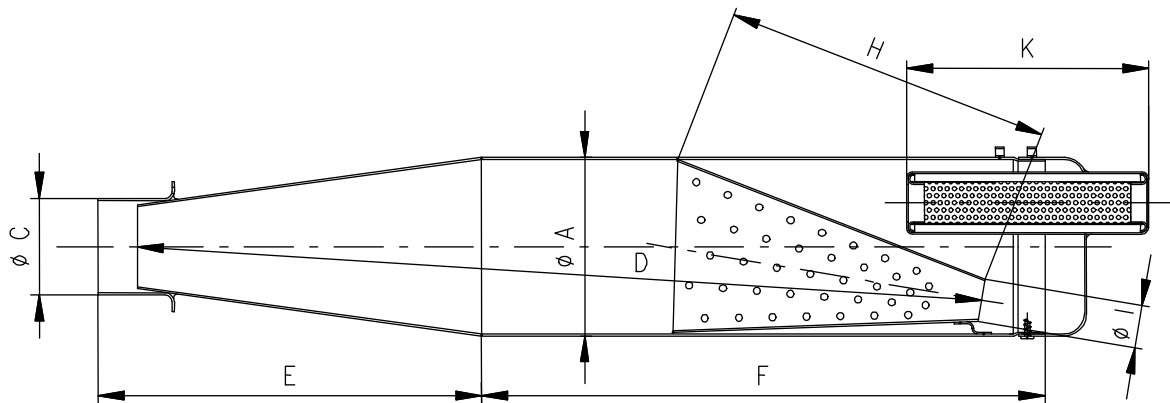

A: $100 \pm 1 \phi_{ext.}$	E: 218 ± 5	H: 180 ± 5
C: $54 \pm 1 \phi_{ext.}$	K: 130 ± 3	l: $24 \pm 2 \phi_{ext.}$
D: 485 ± 5	F: 315 ± 3	

Min. weight 1.39 Kg
Poids min. 1.39 Kg

WIRING DIAGRAM (SELETTRA DIGITAL "K" IGNITION)
 SCHEMA CIRCUIT ELECTRIQUE (ALLUMAGE SELETTRA DIGITAL "K")

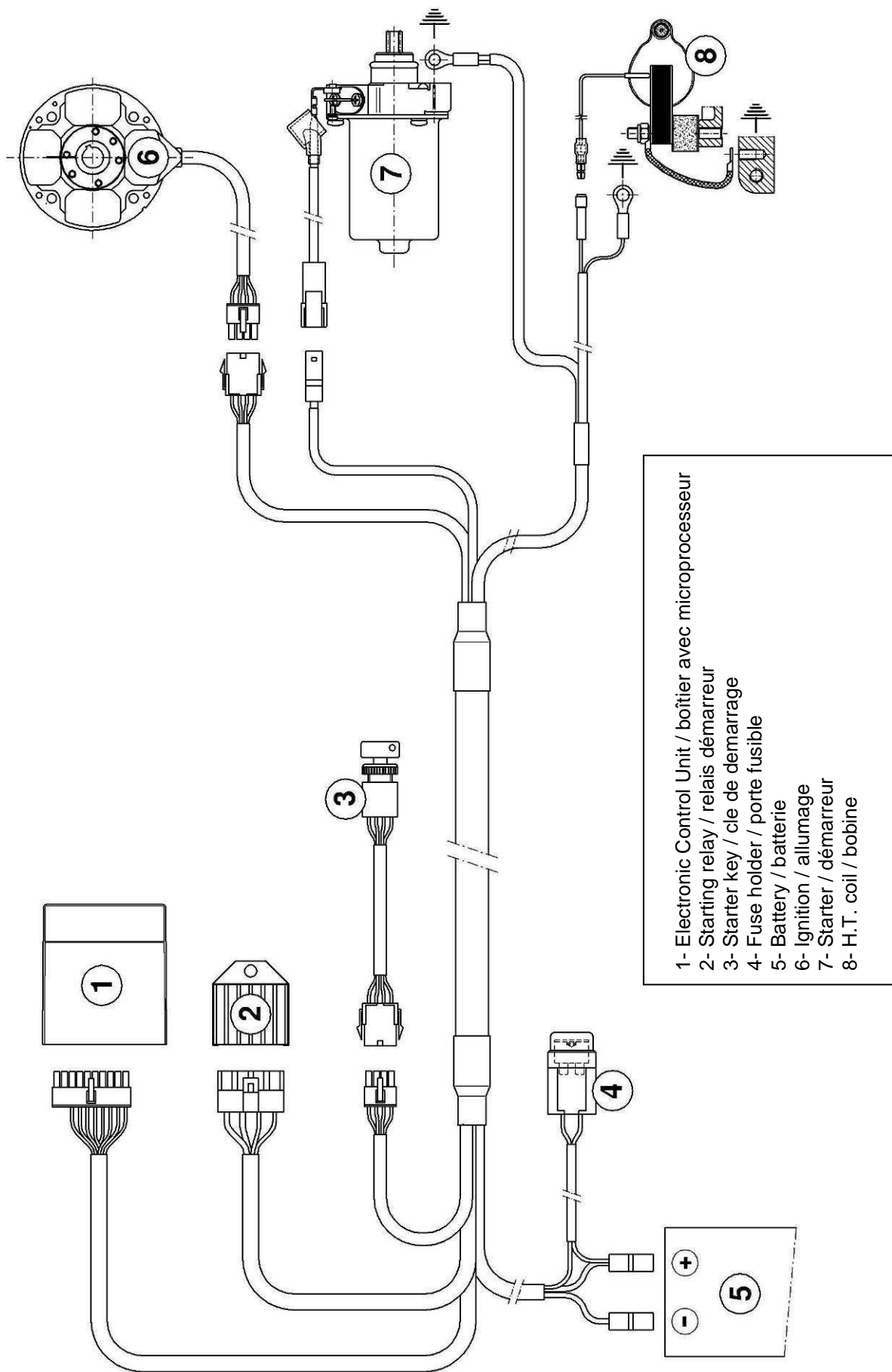

WIRING DIAGRAM (PVL IGNITION, 1ST TYPE)
 SCHEMA CIRCUIT ELECTRIQUE (ALLUMAGE PVL, 1^{ER} TYPE)

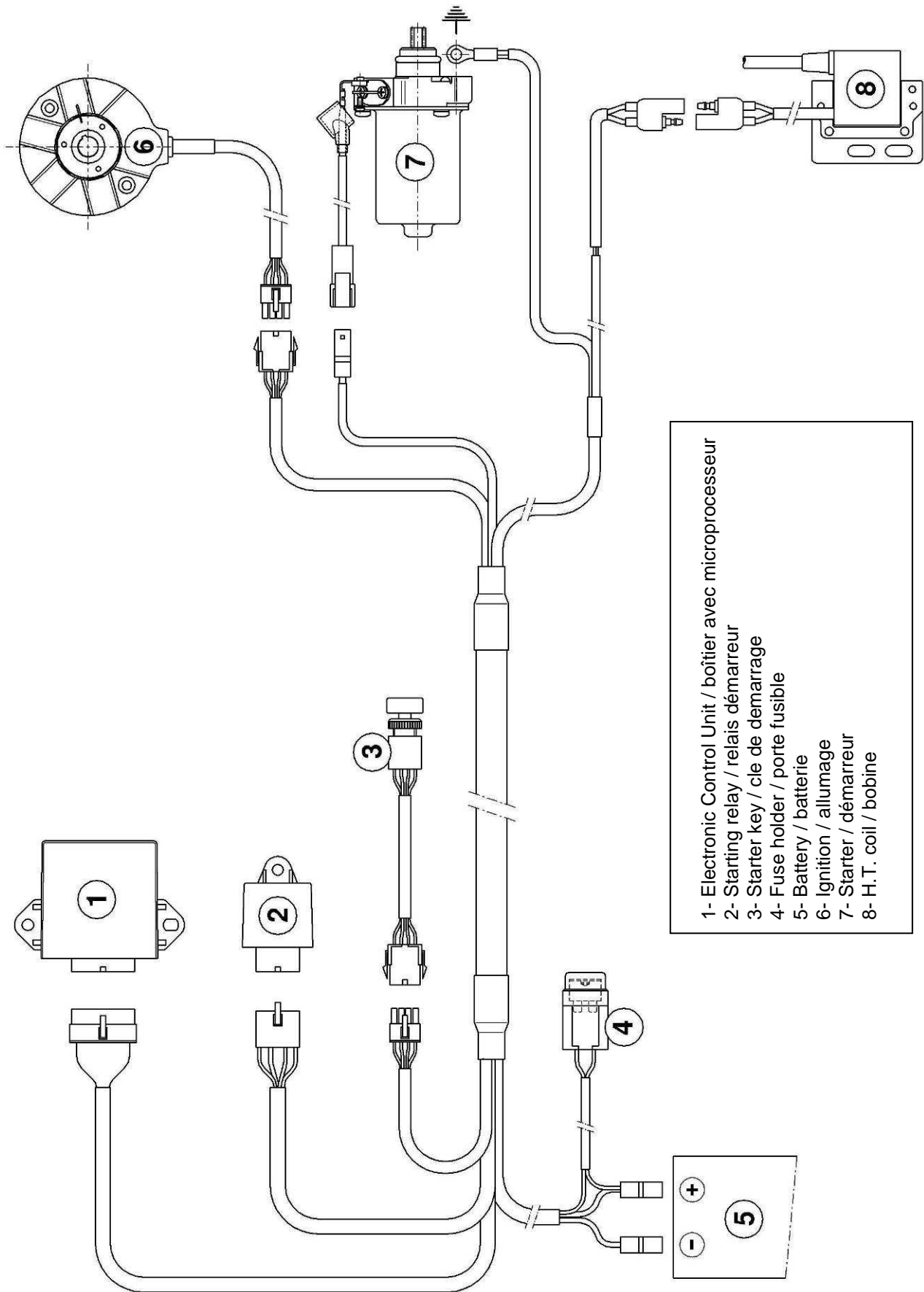

- 1- Electronic Control Unit / boîtier avec microprocesseur
 2- Starting relay / relais démarrage
 3- Starter key / cle de démarrage
 4- Fuse holder / porte fusible
 5- Battery / batterie
 6- Ignition / allumage
 7- Starter / démarreur
 8- H.T. coil / bobine

WIRING DIAGRAM (PVL IGNITION, 2nd TYPE)
 SCHEMA CIRCUIT ELECTRIQUE (ALLUMAGE PVL, 2^{ème} TYPE)

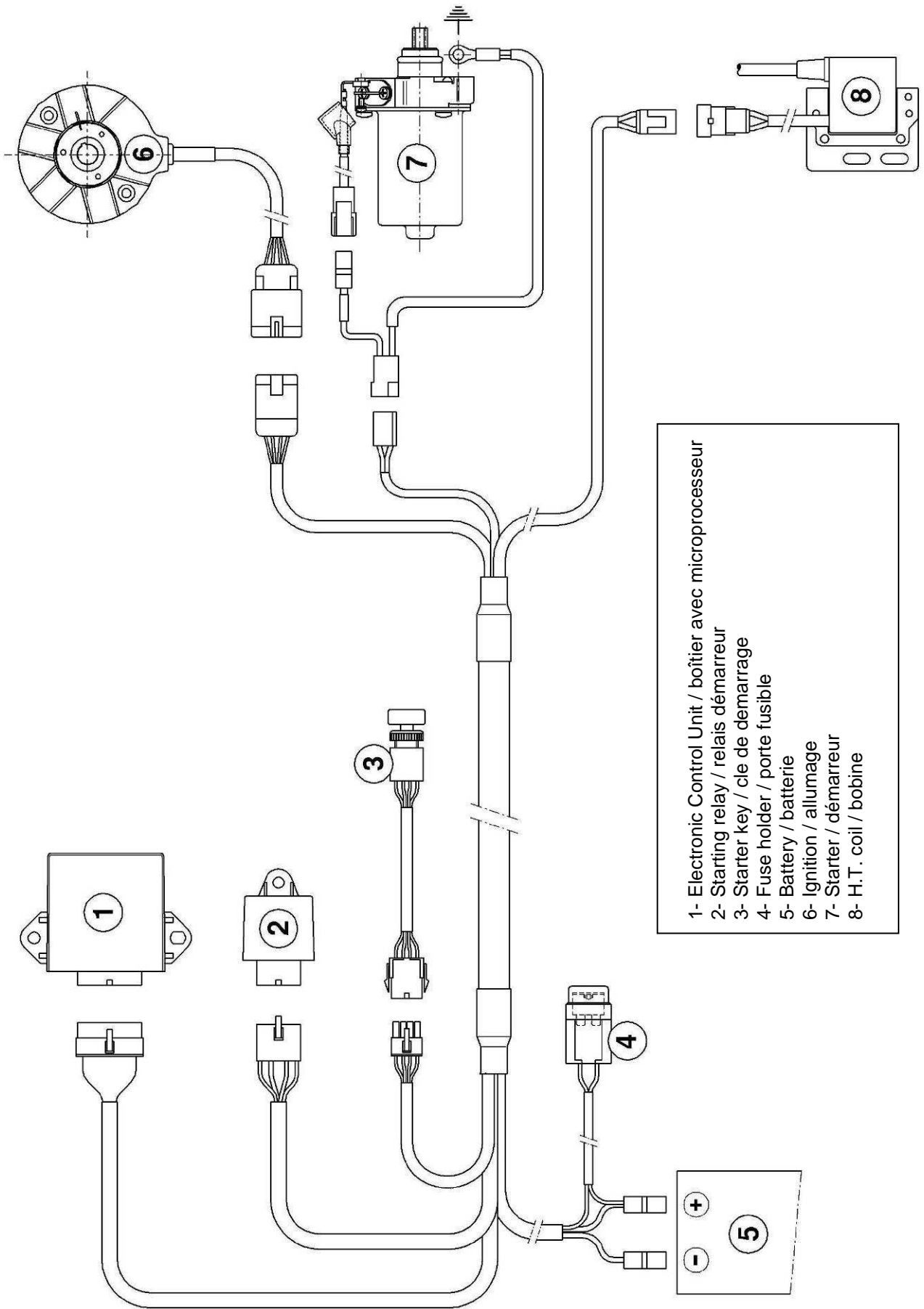

- 1- Electronic Control Unit / boîtier avec microprocesseur
- 2- Starting relay / relais démarrage
- 3- Starter key / cle de démarrage
- 4- Fuse holder / porte fusible
- 5- Battery / batterie
- 6- Ignition / allumage
- 7- Starter / démarrage
- 8- H.T. coil / bobine

ELECTRONIC BOX MARKING
MARQUAGE DU BOITIER ELECTRONIQUE

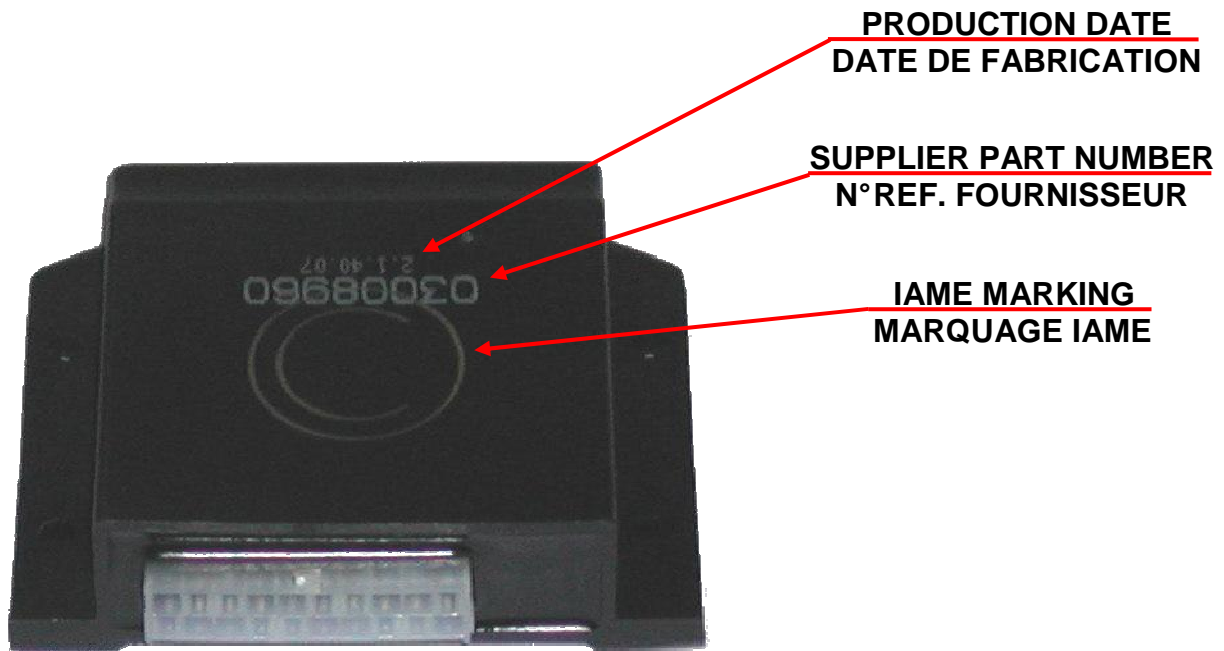

GEAR ALTERNATIVE FIXING
FIXATION ALTERNATIVE DE L' ENGRANAGE

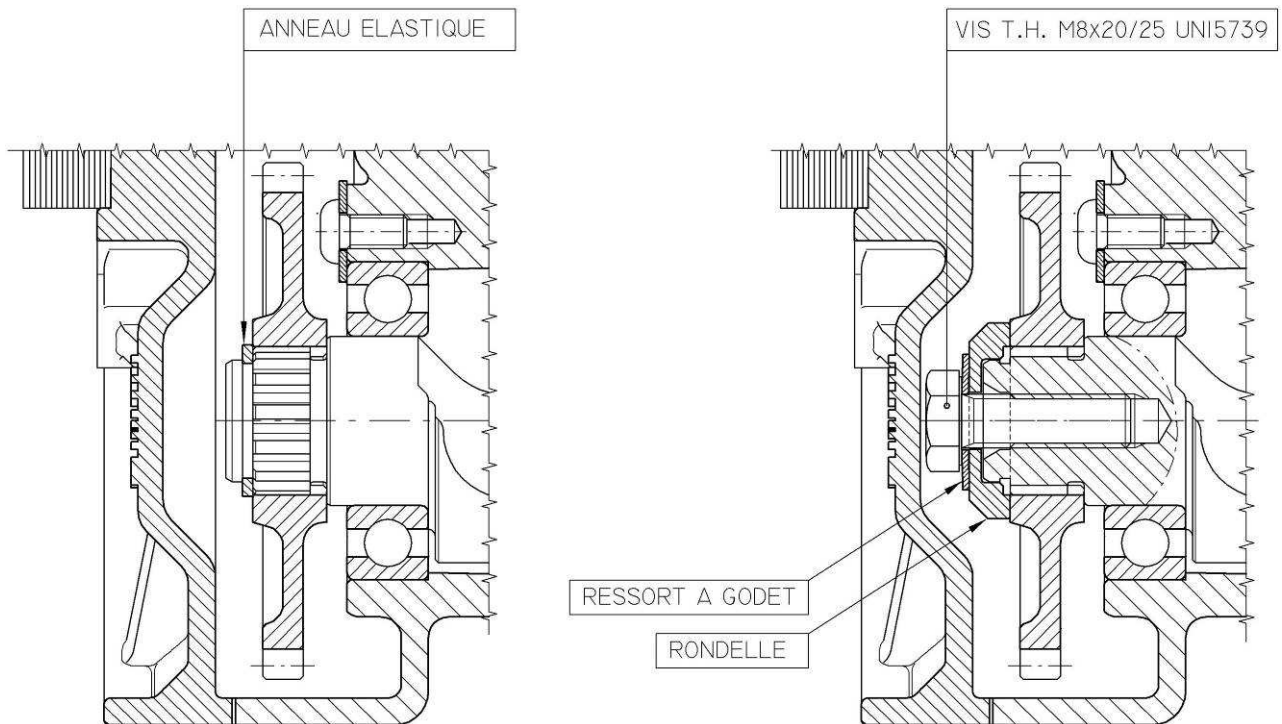

CARBURETTOR COVER ALTERNATIVE
ALTERNATIF COUVERCLE CARBURATEUR

EN PRODUCTION JUSQU' EN
SEPTEMBRE 2007

EN PRODUCTION A PARTIR
D' OCTOBRE 2007

IN PRODUCTION UNTIL
SEPTEMBER 2007

IN PRODUCTION STARTING
FROM OCTOBER 2007

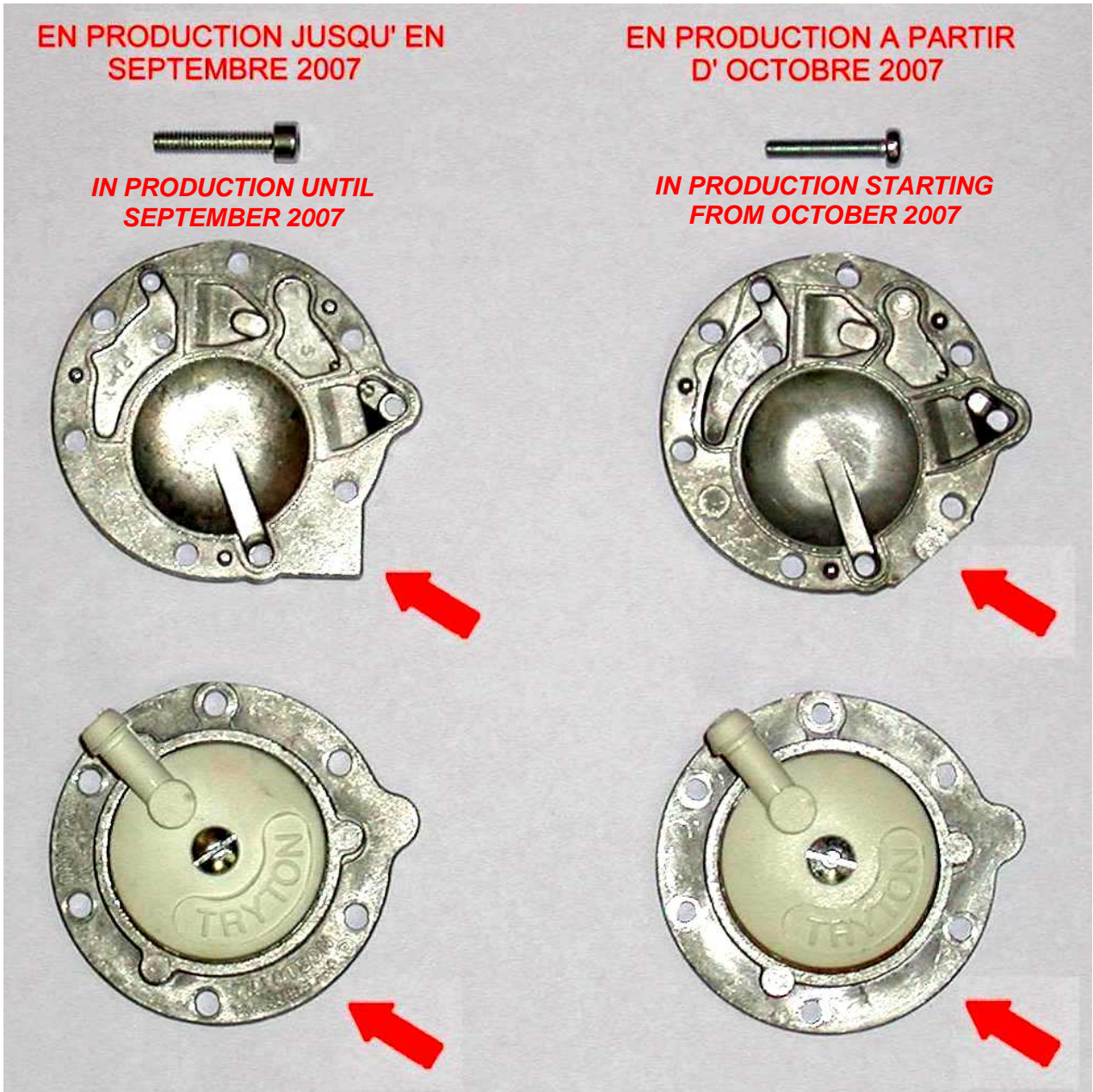

EN PRODUCTION JUSQU' EN
DECEMBRE 2008

EN PRODUCTION A PARTIR
DE JANVIER 2009

IN PRODUCTION UNTIL
DECEMBER 2008

IN PRODUCTION STARTING
FROM JANUARY 2009



DESCRIPTION OF THE CLUTCH - *DESCRIPTION DE L' EMBRAYAGE*

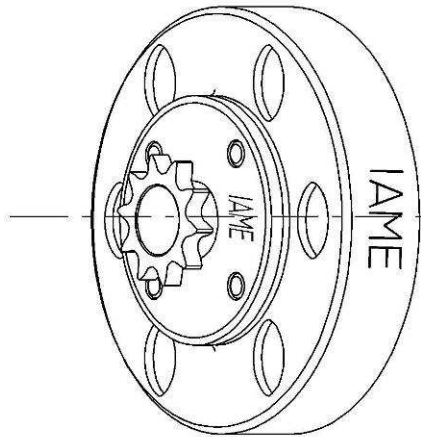

Min. weight 300 g
Poids min. 300 g

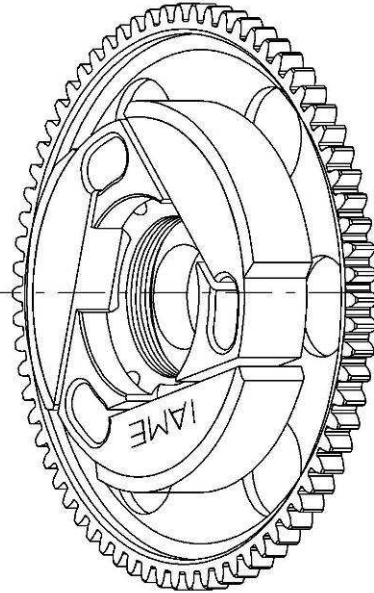

Min. weight 650 g
Poids min. 650 g